

## MAXI MIXTA KOMPACT

- Automatic line, designed to produce baguette, standard bread, ½ baguette, small bread, rustic bread with pointed ends, etc.
- Automatic panning, into a tray, corrugated tray, flat tray or board.
- Its special process and good treat to the dough, allows to produce high quality bread.
- It has a cutting system into: 2, 3, 4, 5, or 6 pieces. Accurate and high quality bread after baking.
- The already cut pieces are separate by some adjustable mobile bands.
- Width of the loading area: 1150 mm max.
- Maximum production: 2000 pph individual piece.
- Cutted pieces: 3500 to 9000 pph.

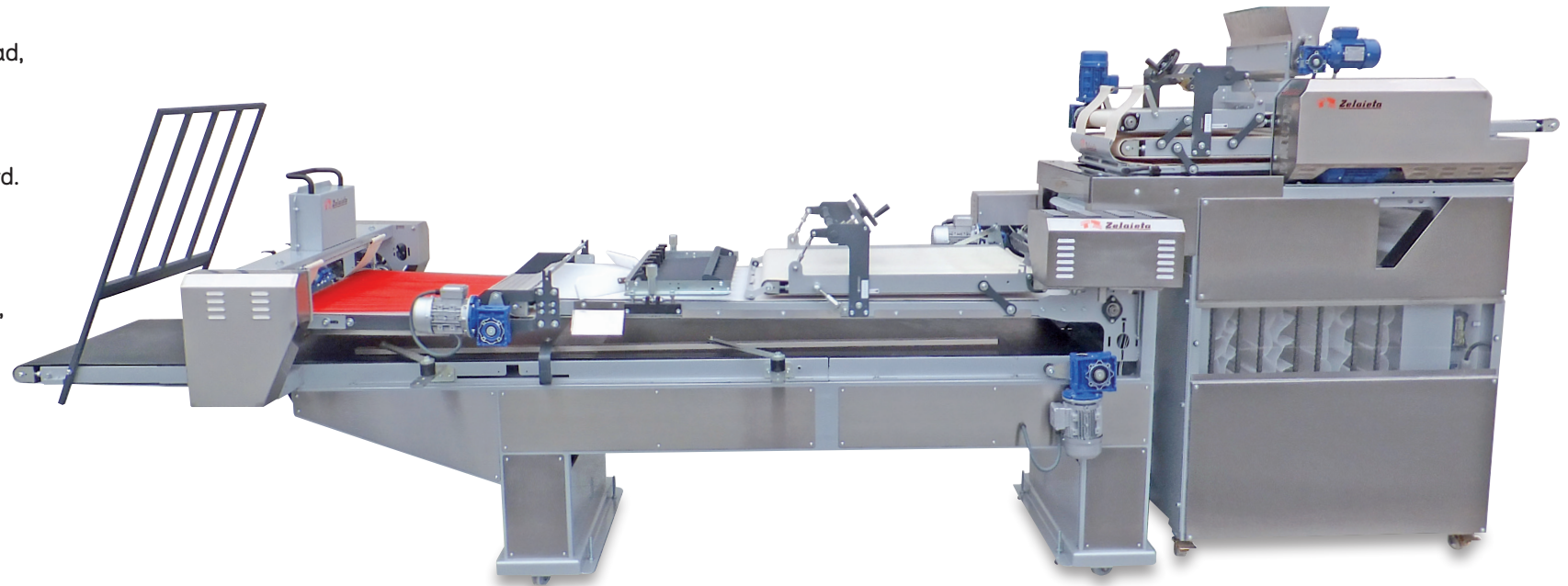

Types of bread

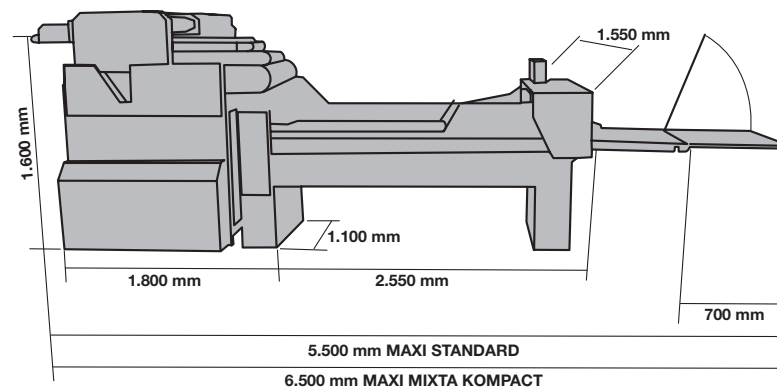

### ASSEMBLY OPTIONS

